

Panel Guide 2024



CONTENT

ROLL UP CLASSIC	3
ROLL UP PROFESSIONAL.....	3
ROLL UP COMPACT.....	3
4 SCREEN CLASSIC.....	3
POLE SYSTEM.....	3
POP UP MAGNETIC	4-6
POP UP MAGNETIC TOWER.....	4-5
CASE & COUNTER.....	7
STANDARD CASE.....	7
FABRIC SYSTEM	8-9
LIGHT FRAME	10-11
CLASSIC FRAME	12-15
FABRIC STAND.....	16
MONITOR STAND.....	16
LIGHT FRAME MINI.....	17
LIGHT FRAME COUNTER.....	17
FOLD OUT COUNTER.....	17
MAGNET FRAME.....	18
PANEL BASE.....	19
STAND UP.....	19
SOFT IMAGE	20
SOFT IMAGE COUNTER	20
INFO STAND	21
PORTABLE TABLE	21
BROCHURE STAND.....	21
BROCHURE STAND DOUBLE	21
GRAPHIC PROFILE	21

VISIT WWW.EXPOLINC.US FOR SET-UP MOVIES AND DOWNLOADS

Roll Up

Product	Panel size standard	Visible size standard	Panel size telescopic rod	Visible size telescopic rod	Weight
Roll Up Classic 700 #4407	27.5 x 86.6	27.5 x 76.8	x	x	8.5
Roll Up Classic 850 #4408	33.5 x 94.5	33.5 x 84.6	33.5 x 98	33.5 x 64 - 87	10.0
Roll Up Classic 1000 #4410	39.4 x 94.5	39.4 x 84.6	39.4 x 98	39.4 x 64 - 87	11.4
Roll Up Classic 1150 #4411	45.3 x 94.5	45.3 x 84.6	45.3 x 98	45.3 x 64 - 87	12.8
Roll Up Classic 1450 #4414	57.1 x 94.5	57.1 x 84.6	57.1 x 98	57.1 x 64 - 87	16.0
Roll Up Professional 850 #4428	33.5 x 94.5	33.5 x 84.6	x	x	10.5
Roll Up Professional Double #4429	33.5 x 94.5	33.5 x 84.6	x	x	16.0
Roll Up Compact 850 #6300	x	x	33.5 x 95	33.5 x 64 - 87	7.5
Roll Up Compact 1000 #6301	x	x	39.4 x 95	39.4 x 64 - 87	8.1

When using 96.5" supporting rod the panel length is 106" with the visible being 96.5".
 When using 57" supporting rod the panel length is 67" with the visible size being 57".
 Maximum panel thickness is 17 mil. When using 96.5" supporting rod or stiff material, the recommended thickness is 10.5 - 13 mil. If uncertain we recommend to make tests with different materials.

4 Screen Classic

Product	Panel size	Visible size	Weight
4 Screen Classic 550 #4455	21.6 x 58.8	21.6 x 58.3	4.2
4 Screen Classic 700 #4457	27.5 x 77.2	27.5 x 76.7	4.8
4 Screen Classic 850 #4458	33.5 x 85	33.5 x 84.5	5.5
4 Screen Classic 1000 #4460	39.4 x 85	39.4 x 84.5	5.9
4 Screen Classic 1150 #4461	45.3 x 85	45.3 x 84.5	9.0
4 Screen Classic 1450 #4464	57.1 x 85	57.1 x 84.5	10.3
44 Screen Classic 2000 #4465	78.7 x 85	78.7 x 84.5	11.7

4 Screen can handle most materials up to 17 mil thickness (paper, vinyl, pvc, textile).

Pole System

Product	Panel size width	Panel size height	Weight
Pole System 550	21.6	39 - 94	5.7
Pole System 700	27.5	39 - 94	5.9
Pole System 850	33.5	39 - 94	6.2
Pole System 1000	39.4	39 - 94	6.4

Pole System can also be used as double sided. In this case extra panel profiles should be added. Pole System can handle most materials up to 17 mil thickness (paper, vinyl, pvc, textile). Total height of the system is min 39" and maximum 96".

Panel profile dimension sketch

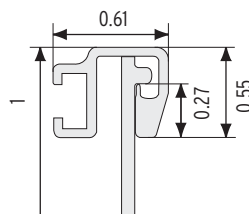

Pop Up Magnetic - panel sizes

Curved system

Product	Standard height	98.4 height (3 quads +)	118.1 height (4 quads)
Curved, inside	26.5 x 87.5	26.5 x 97.75	26.5 x 116.4
Curved, outside	31.75 x 87.5	31.75 x 97.75	31.75 x 116.4
Side panel, curved	26.5 x 87.5	26.5 x 97.75	26.5 x 116.4
Side panel, straight	11.5 x 87.5	11.5 x 97.75	11.5 x 116.4
Curved, inside for Tabletop	26.5 x 58.5		

RECOMMENDED PANEL THICKNESS 17-21 MIL.

Straight system

Product	Standard height	98.4 height (3 quads +)	118.1 height (4 quads)
Straight panel	28.8 x 87.5	28.8 x 97.75	28.8 x 116.4
Side panel, curved	28.8 x 87.5	28.8 x 97.75	28.8 x 116.4
Side panel, straight	11.5 x 87.5	11.5 x 97.75	11.5 x 116.4
Straight panel for Tabletop	28.8 x 58.5		

RECOMMENDED PANEL THICKNESS 17-21 MIL.

Connected systems

Product	Standard height	98.4 height (3 quads +)	118.1 height (4 quads)
Straight connection	28.8 x 87.5	28.8 x 97.75	28.8 x 116.4
90° connection with panel, inside	10.4 x 87.5	10.4 x 97.75	10.4 x 116.4
90° connection with panel, outside	28.8 x 87.5	28.8 x 97.75	28.8 x 116.4
90° connection with profile, outside	20.9 x 87.5	20.9 x 97.75	20.9 x 116.4

RECOMMENDED PANEL THICKNESS 17-21 MIL.

Pop Up Magnetic - weights

Product	Basic		Travel		Standard		Case & Counter*		Top shelf
	Curved	Straight	Curved	Straight	Curved	Straight	Curved	Straight	C&C
Package 2x3	19	19	34	35	51	51	58	59	11.7
Package 3x3	23	24	39	40	56	57	64	65	11.7
Package 4x3	27	28	44	45	60	62	68	69	11.7

*The top shelf is not included in the Case & Counter package.

Pop Up Tower

Product	Qty panels	Panel size	Diameter	Weight
Tower 3 squares high #7003	3 pcs	26.5 - 87.5	118	12

Tower panel thickness should be 14 - 18 mil, as they should be pliable. These panels should not have kickers.

Pop Up Magnetic - accessories

Product	Standard height + recommended width
Curtain #7057	87.2 x 51.2

Product	Maximum load straight system	Maximum load curved system	Weight
Screen Holder #7070	13.2*	17.6	1.6
Shelf Kit #7077	4.65*	6.65	5.3

* Stabilizing feet should be used for straight system. Screen Holder and Shelf Kit may only be used with Expolinc Pop Up Magnetic.

Pop Up Magnetic - dimension sketches

Example 3 squares

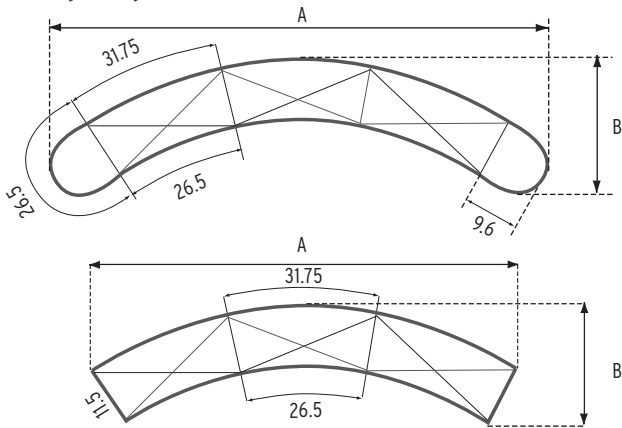

Curved system

Width	Curved side panels		Straight side panels	
	A	B	A	B
1 square	48.7	14.7	33.3	13.8
2 squares	75.3	20.1	63.2	18.1
3 squares	99.8	28.9	90.1	25.1
4 squares	120.5	38.2	112.6	34.5
5 squares	141.7	49.2	129.5	45.7

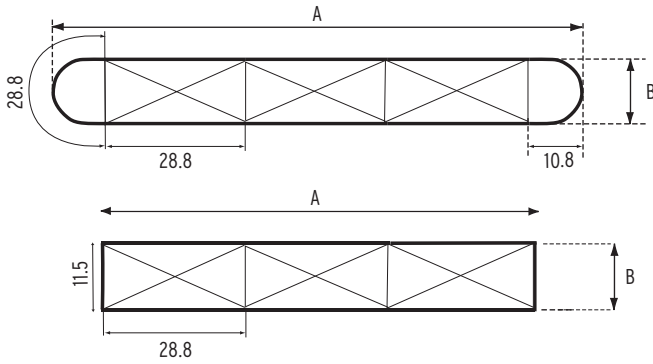

Straight system

Width	Curved side panels		Straight side panels	
	A	B	A	B
1 square	50.5	12.4	30.7	12.4
2 squares	79.4	12.4	59.5	12.4
3 squares	108.2	12.4	88.4	12.4
4 squares	137.0	12.4	117.2	12.4
5 squares	166.0	12.4	146.1	12.4

Straight connection

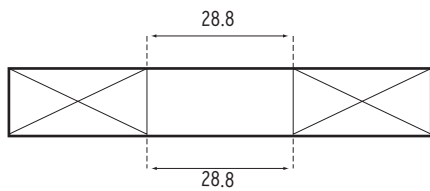

90° connection with panel

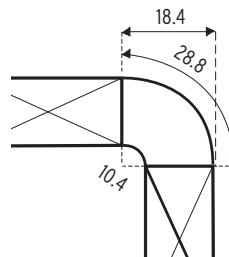

with profile

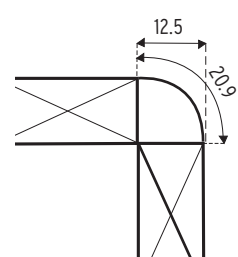

Radius

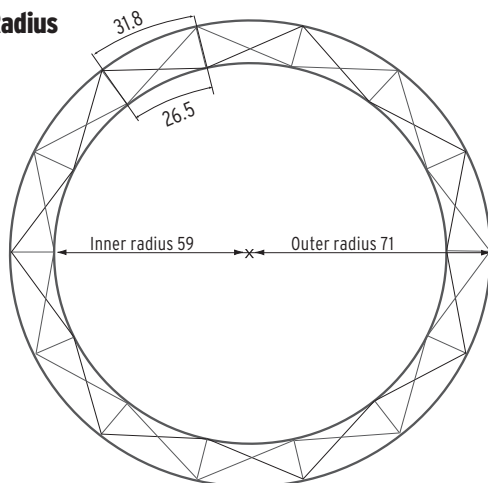

Tower

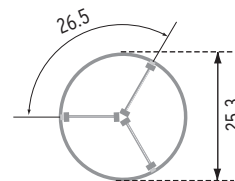

Screen Holder & Shelf kit

Position of holes in panel for Screen Holder/Shelf kit

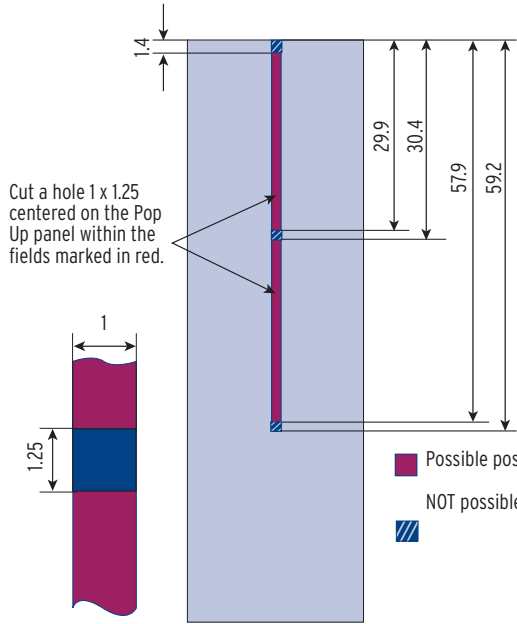

Shelf Kit

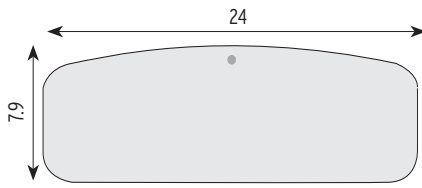

Screen plate & VESA 100 & 200 Hole spacing

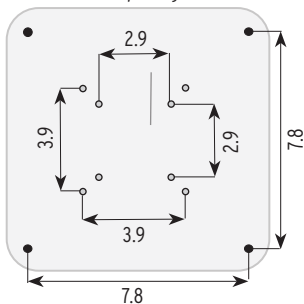

Screen Holder

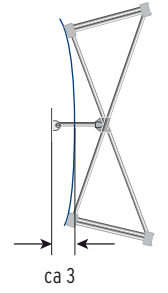

Suspension options

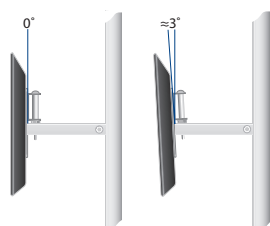

Showcase

Standard height

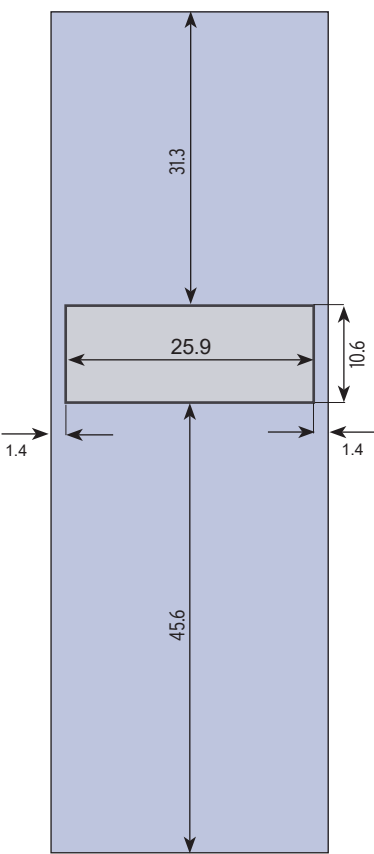

98.4 height

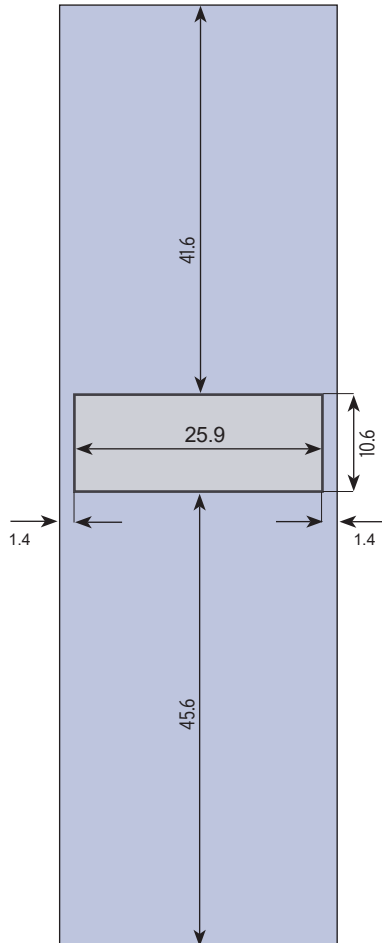

Panel size - backpanel

Minimum size 28.8 x 12.6
 Also add the required quantity of magnetic bars for the backpanel.

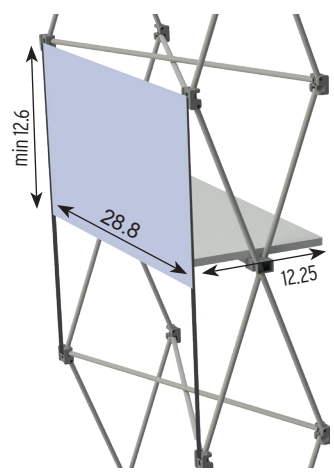

Load limit per shelf is 20 lbs

Transport boxes

Product	Panel size	Weight
Case & Counter #7375	71.6 x 36.2	40*
Double Case & Counter	113.3 x 36.2	80*
Standard Case #7450	62.4 x 33.1	30

*Top shelf is not included in Case & Counter. Weight top shelf 12 lb, top shelf double Case & Counter 16 lb.
Recommended panel thickness 13-18 mil.

Case & Counter

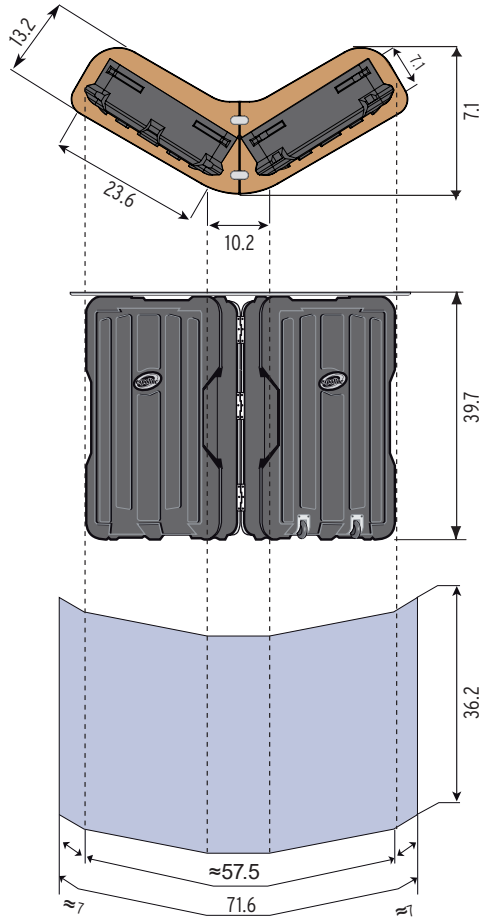

Standard Case

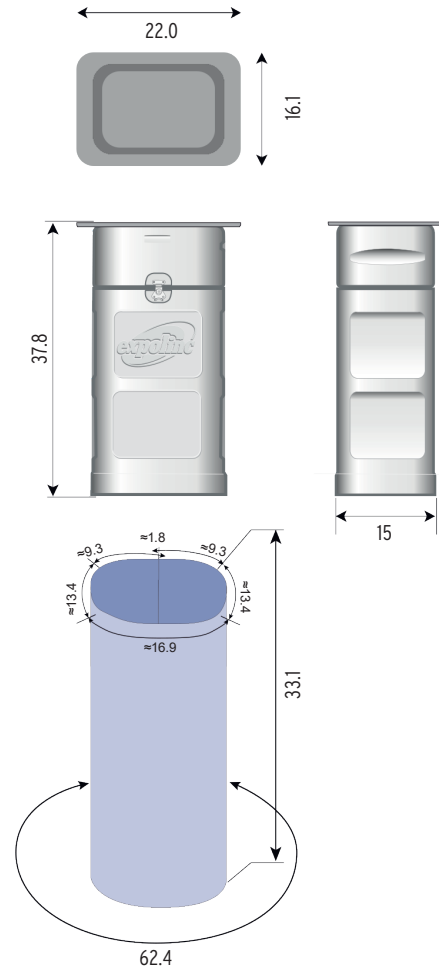

Double Case & Counter

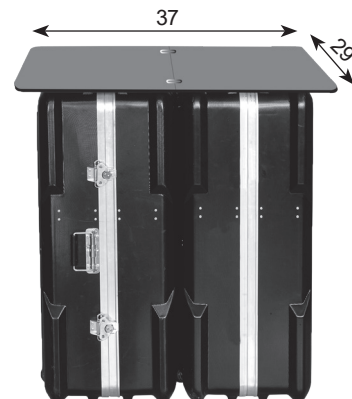
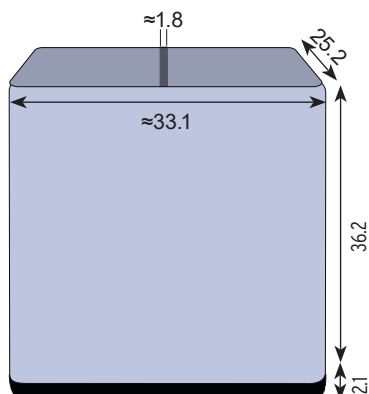

Fabric System

Product	Max building width inches	Graphic height inches	Graphic width inches
2 Poles straight	173	39.3 - 108	Profile lengths+sides
2 Poles curved 15°	173	39.3 - 108	Profile lengths+sides
3 Poles curved 15°	260	39.3 - 108	Profile lengths+sides
3 Poles straight	260	39.3 - 108	Profile lengths+sides
3 Poles curved 90°+straight	268	39.3 - 108	Profile lengths+sides

Max system height 114

Profile lengths

Straight profile,	43.3
Curved profile 15°, inner radius	43.3
Curved profile 15°, outer radius	43.3
Curved profile 90°, inner radius	51.2

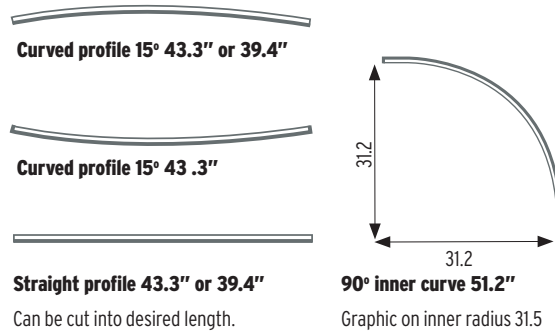

Weight packages

Weight packages	Weight*
Soft bag and 2 poles	36.6
Standard Case XL and 2 poles	63.14
Standard Case XL and 3 poles	77.2
Profiles, straight and curved 15°	1.2
Profile curved 90°	1.3

*Weight excl profiles. Combine packages for larger building widths.



Recommended size of the graphic strip is 3x12-14mm soft PVC or silicone.



Add 4" on each side to fold sides + seams at the top and bottom.

Standard Case XL

Product	Panel size	Weight
Standard Case XL #7550, 7551	62.4 x 33.1	25.5
Standard Case XL #7550, 7551	62.4 x 42.3 with lid	25.5

Recommended panel thickness 13-18 mil. *Top shelf, locking kit and cardboard tube for panel are not included in Standard Case XL. Weight top shelf 12 lbs.

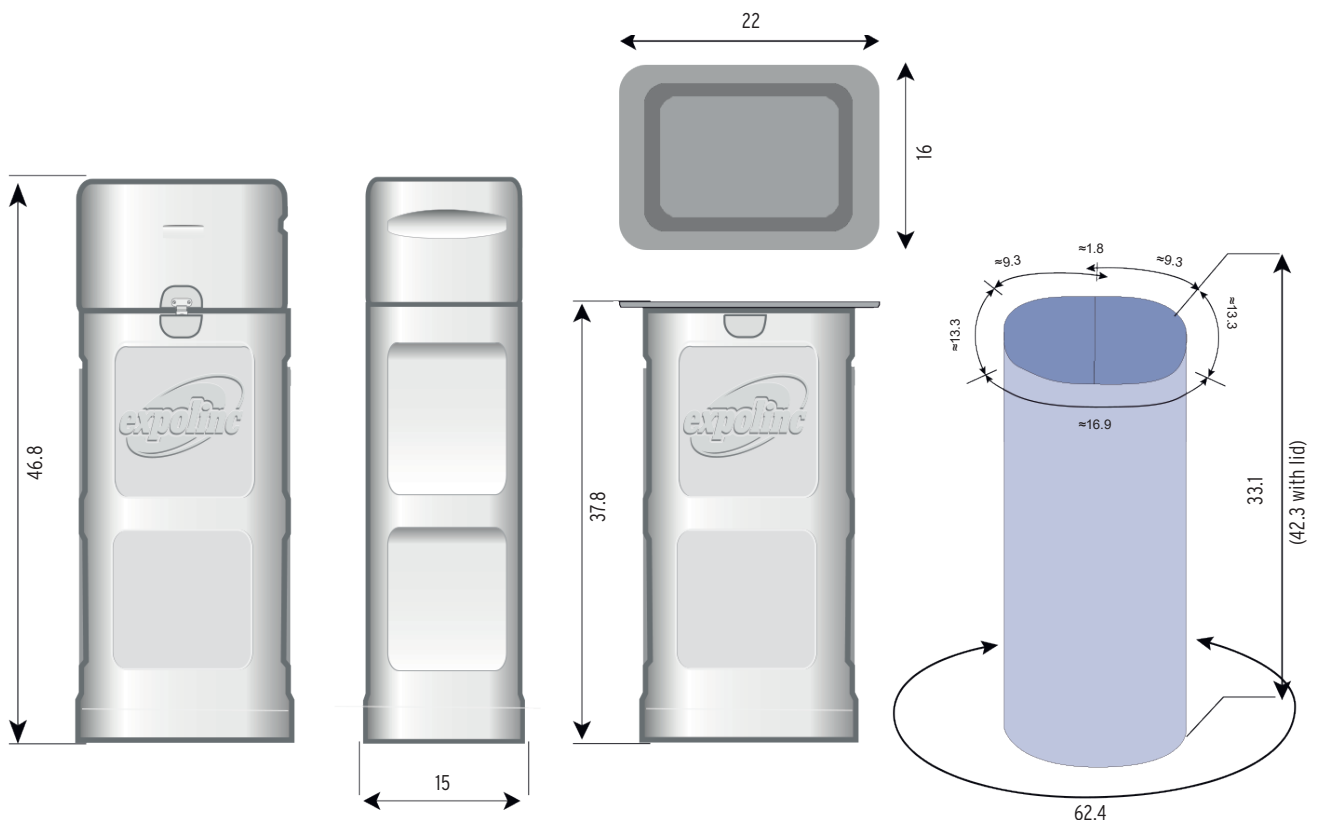

Some examples

Top and bottom profiles





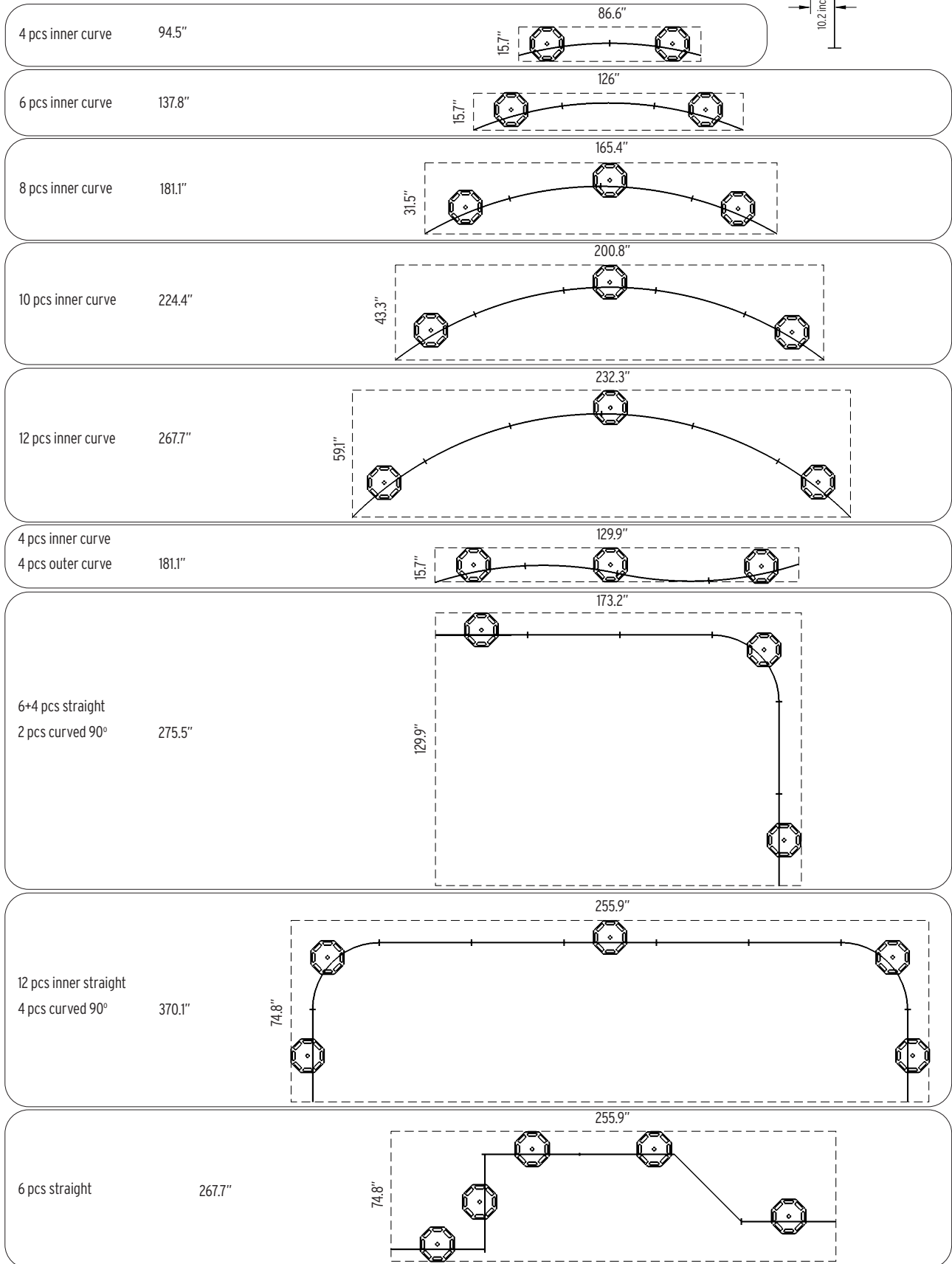
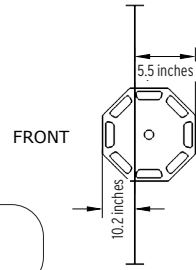

Graphic width incl. 4" on each side

Total curve 30-45-60-75
and 90 degrees



Light Frame (New version from March-2024)

Profiles

Light Profile #7200-1	 19.6"
Light Profile #7202-1	 34.4"
Light Profile #7203-1	 39.3"
Profile 250 #7204	 9.8"
Profile 500 #7205	 19.6"
Profile 954 #7206	 37.5"
Profile 1000 #7207	 39.3"

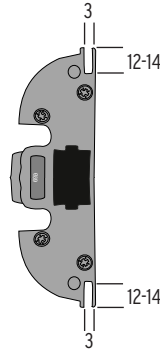

Packages

Weight
Basic/Standard Case XL/Travel

37.7x98.4	63/82/63
77.2x98.4	79/98/79
116.6x98.4	96/113/95
155.9x98.4	113/130/112

Recommended max size SEG strip (keder) 12-14mm x 3mm

Graphic sizes - frame outer measurements

Please contact us for other potential sizes

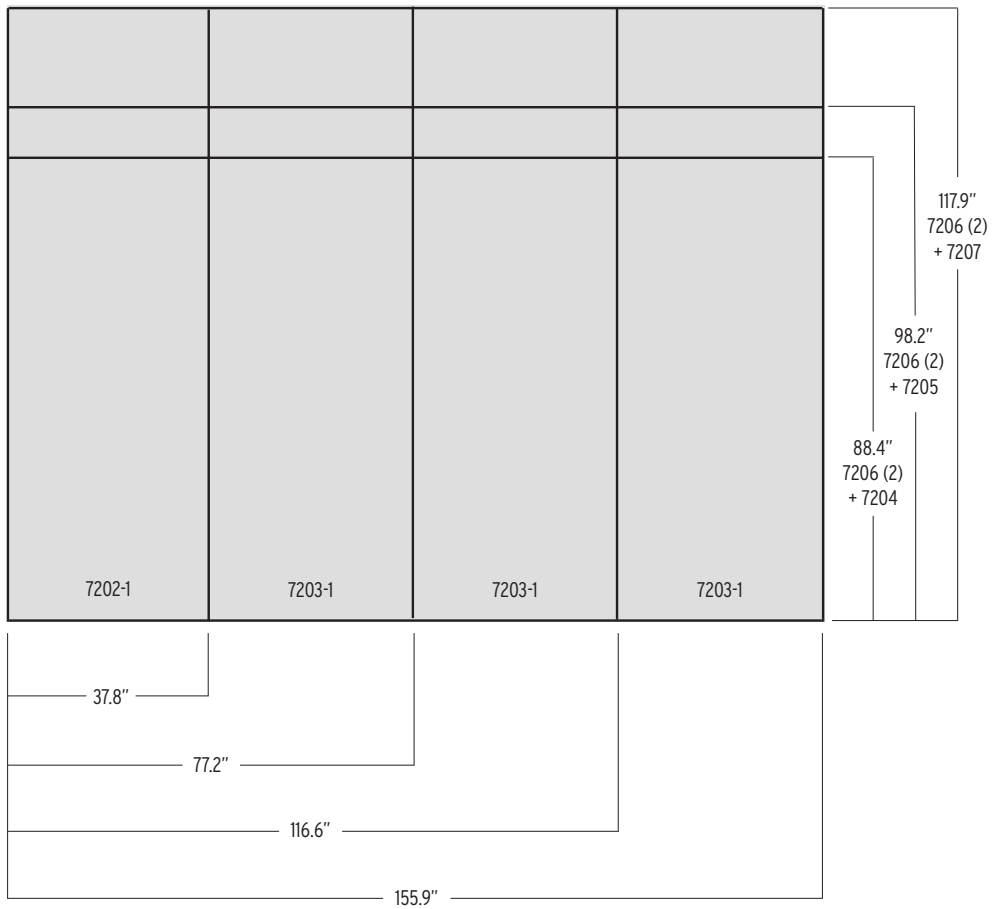

Examples

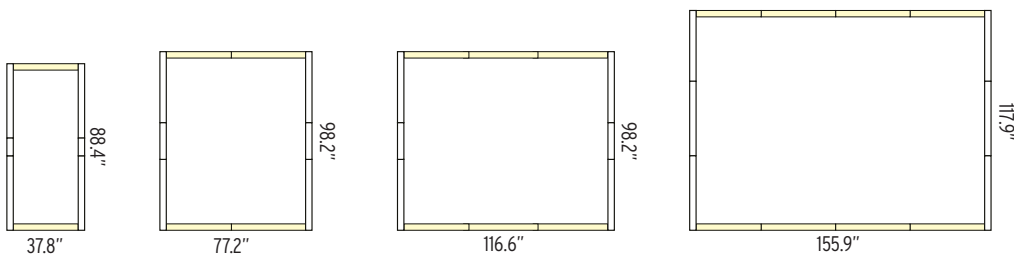

Light Frame (Old version until March-2024)

Profiles

Light Profile #6901		34.4"
Profile 553 #6909		21.8"
Profile 803 #6908		31.6"
Profile 969 #6904		38.1"

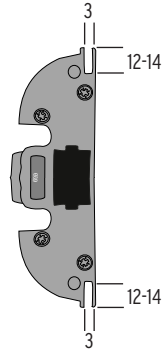

Packages	Weight
	Basic/Standard Case/Travel
37.7x98.4	63/NA/64
72.4x98.4	78/93/77
106.7x98.4	94/106/90
141.3x98.4	110/121/106

Recommended max size SEG strip (keder) 12-14mm x 3mm

Graphic sizes - frame outer measurements

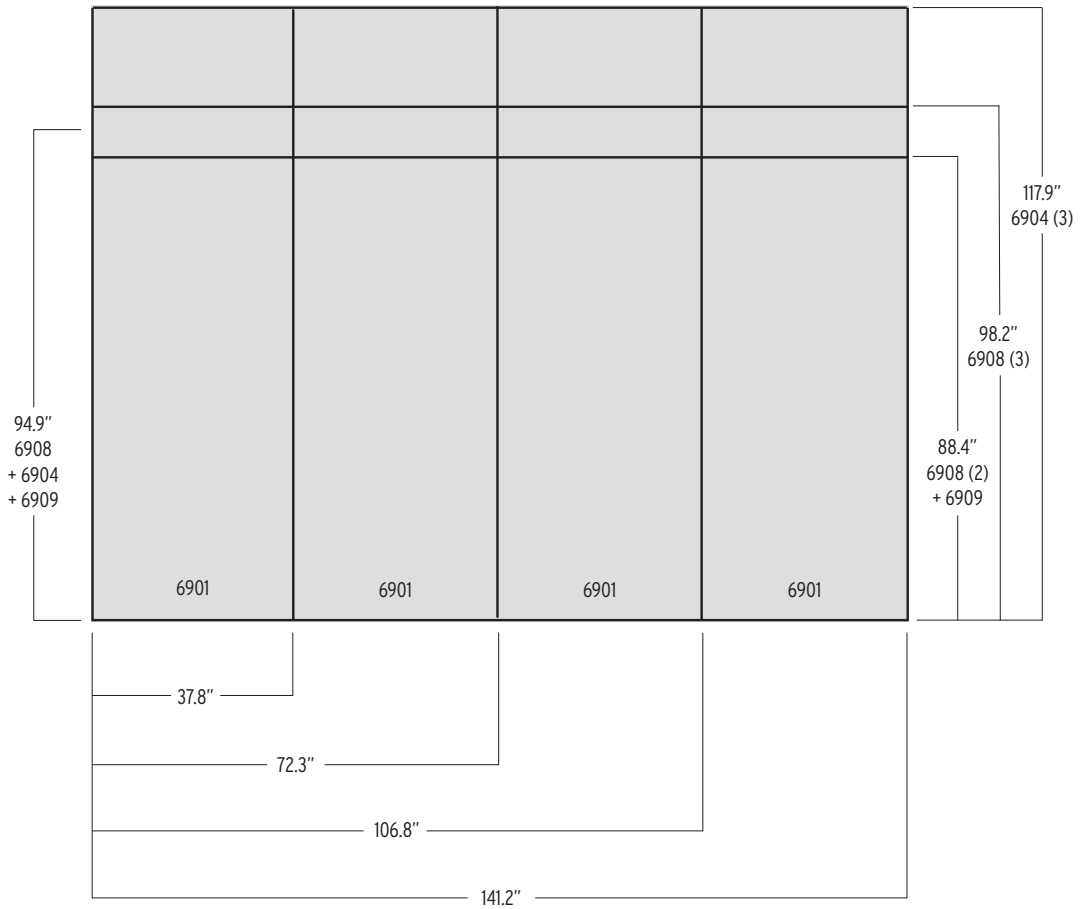

Examples

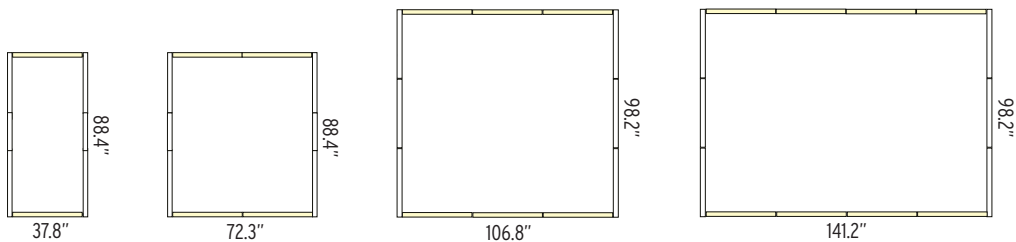

Connectors

1.77" of the graphic will be hidden when connecting more than one Frame.

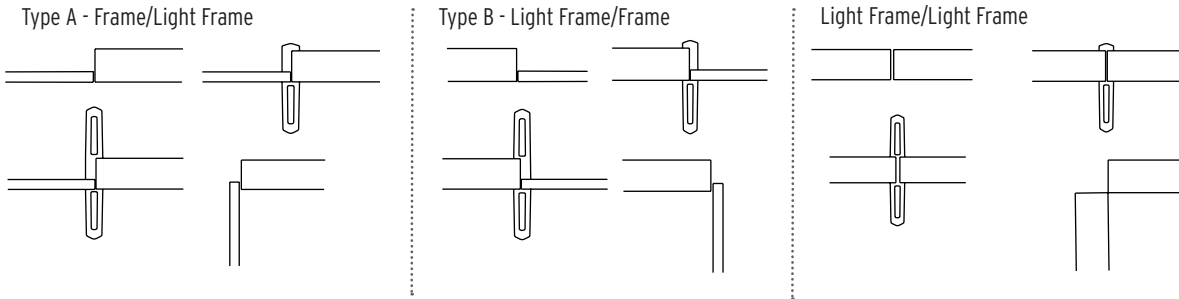

Example - graphic sizes

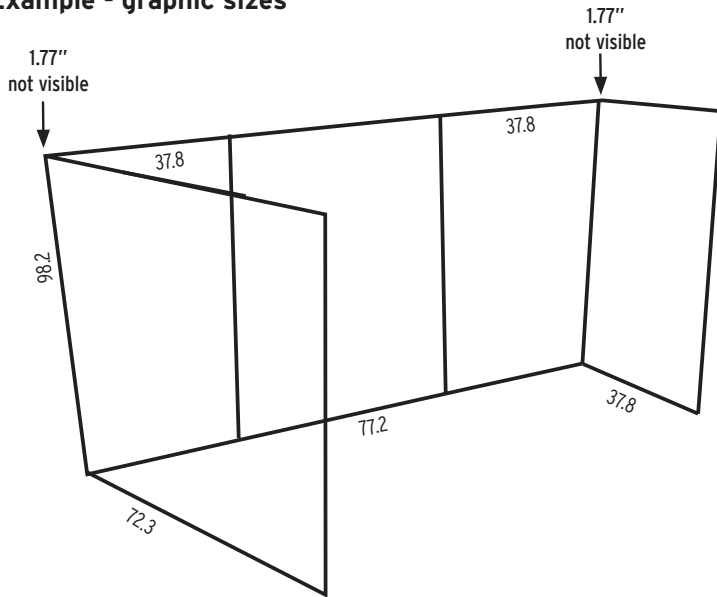

Content

- 2 pcs 72.3x98.2
- 3 pcs 37.8x98.2x98.2
- 2 pcs Connector 90°
- 2 pcs Connector straight,

Stabilizing feet

Product	Weight
Double sided foot, pair (right and left)	9.1
Double sided foot, single	4.6
Single sided foot, pair (right and left)	7.5
Single sided foot, left	3.8
Single sided foot, right	3.8

Supporting feet, double sided and single sided

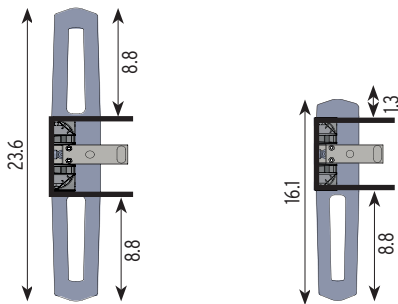

Connecting feet, double sided and single sided

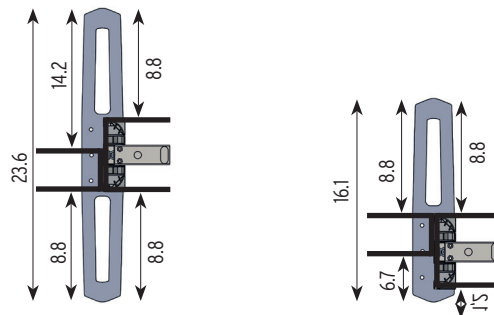

Classic Frame

Profiles

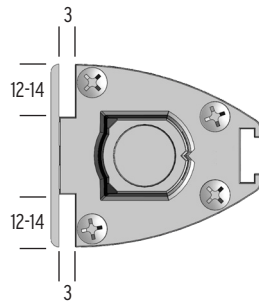
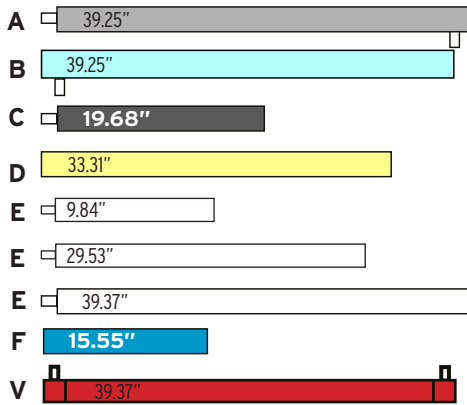

Packages

Weight - lbs
Basic/Travel/Standard Case XL

Package Size	Weight - lbs (Basic/Travel/Standard Case XL)
19.68"x98.22"	21/NA/NA
37.40"x98.22"	23/NA/NA
76.77"x98.22"	30/35/53
116.14"x98.22"	37/42/60
155.51"x98.22"	45/51/68
194.88"x98.22"	55/61/78

Use SEG strip (keder) 12-14mm x 3mm

Graphic sizes - frame outer measurements

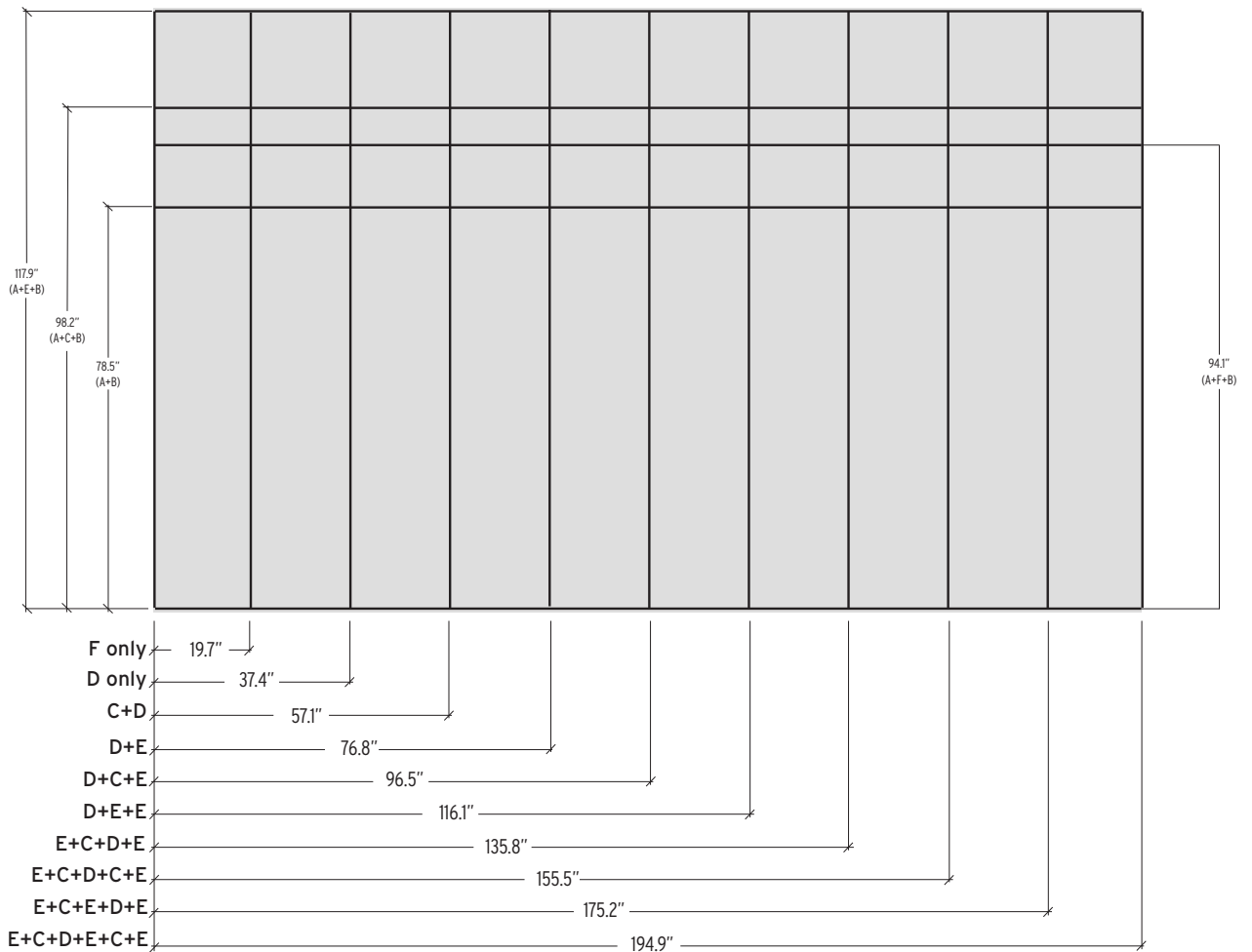

Examples

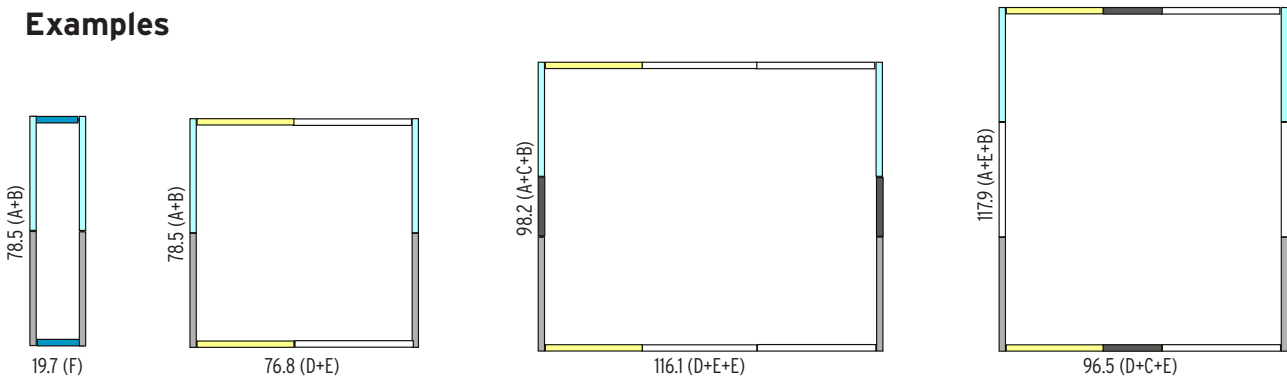

All weights and sizes are in lb or inch, unless otherwise specified. Weights refer to complete package with bag/box without panel. 3
Facts and figures are specified with reservation for product modifications and printing errors.

Classic Frame - Sky Bridge

Graphic sizes - frame outer measurements

Use SEG strip (keder) 12-14mm x 3mm

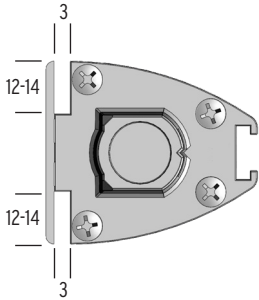
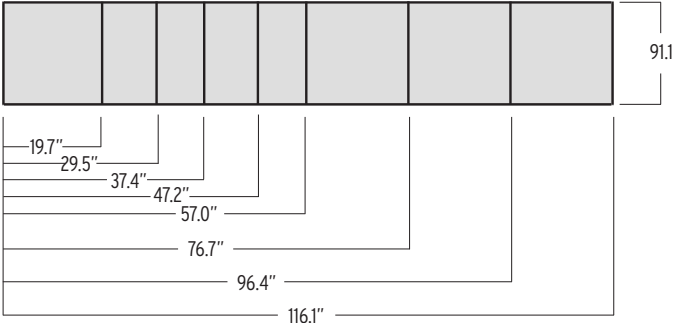

Classic Frame - Header Kit

Graphic sizes - frame outer measurements

Use SEG strip (keder) 12-14mm x 3mm

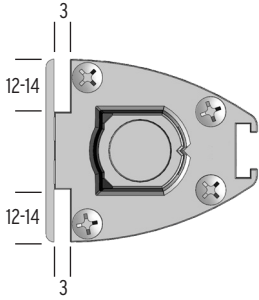
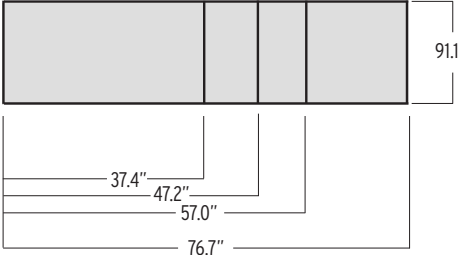

Connectors

With connectors A-C 1.77" of the graphic will be hidden behind the connecting profile.

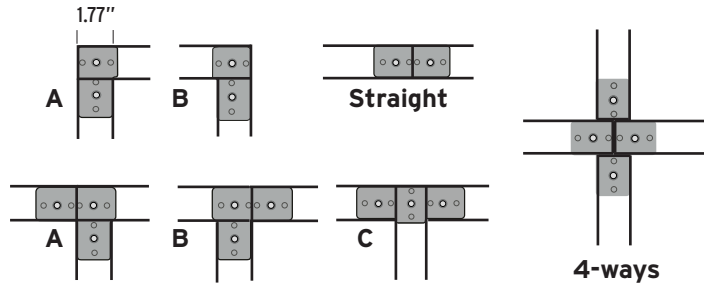

Example - graphic sizes

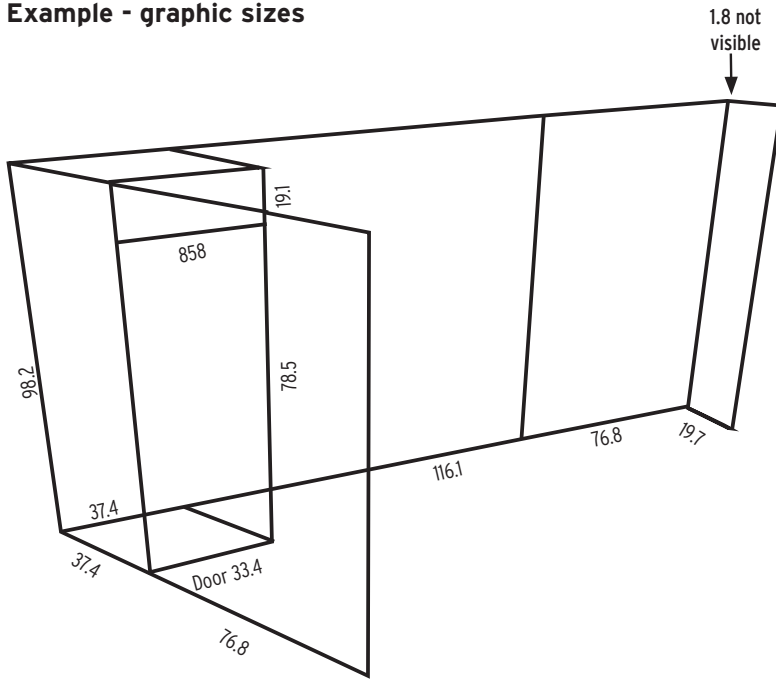

Content

- 2 pcs 76.8 x 98.2
- 1 pc 116.1 x 98.2
- 1 pc 19.7 x 98.2
- 1 storage room, left hung door Connector 90° type B

Stabilizing feet

Product	Weight
Single sided foot	2.13
Double sided foot	3.15
Connecting foot, single sided incl upper straight connector	2.15
Connecting foot, double sided incl upper straight connector	4.10

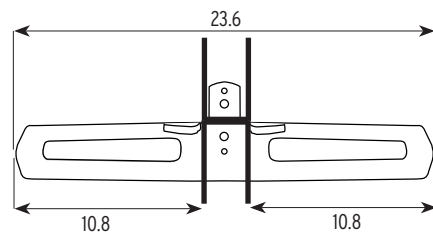
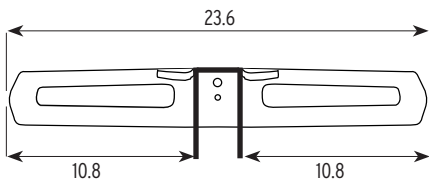
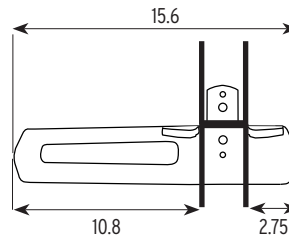
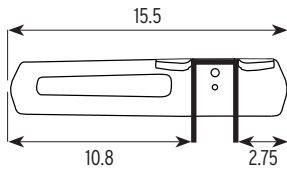

Classic Frame - Storage room

Product	Weight
Storage Room - Standard 98.4 inches	104
Storage Room - Standard 118.1 inches	121
Storage Room - XL 98.4 inches	140
Storage Room - XL 118.1 inches	152

Storage Room - Standard - Outer frame sizes

Standard 98.4 inches - Side	37.4 x 98.2
Standard 98.4 inches - Door	33.4 x 78.5
Standard 98.4 inches - Header above door	33.8 x 9.11
Standard 98.4 inches - side	37.4 x 98.2
Standard 118.1 inches - Door	33.4 x 78.5
Standard 118.1 inches - Header above door	33.8 x 38.8

Standard 98.4 inches

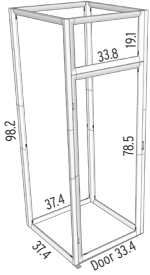

Standard 118.1 inches

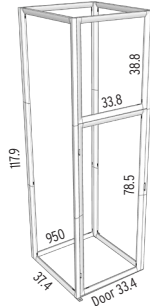

Storage Room - XL - Outer frame sizes

XL 98.4 inches - Side	37.4 x 98.2
XL 98.4 inches - Side	39.4 x 98.2
XL 98.4 inches - Side	76.8 x 98.2
XL 98.4 inches - Door	33.4 x 78.5
XL 98.4 inches - Header above door	33.8 x 91.1
XL 118.1 inches - Side	37.4 x 117.9
XL 118.1 inches - Side	39.4 x 117.9
XL 118.1 inches - Side	76.8 x 117.9
XL 118.1 inches - Door	33.4 x 78.5
XL 118.1 inches - Header above door	33.8 x 38.8

XL 98.4 inches

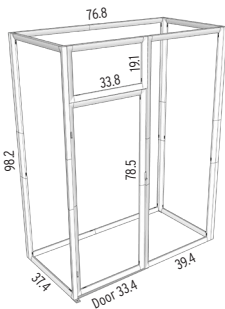

XL 118.1 inches

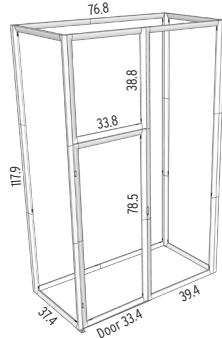

Shelf kit for Storage Room Standard

35.4 x 10.2

Extra shelf for Storage Room Standard

35.4 x 10.2

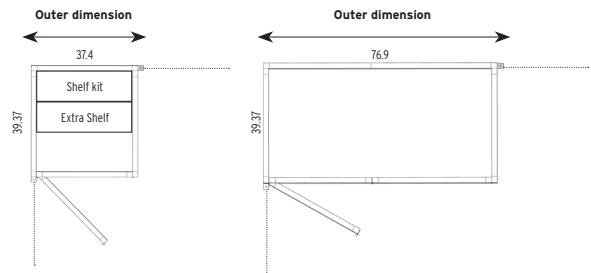

Classic Frame - Counter

Product	No of graphics	Outer frame sizes	Weight*
Classic Frame - counter, 2 m in Standard Case XL	1 pc front	76.8 x 38.9	44
	2 pcs sides	13.3 x 38.9	
Classic Frame - counter, 1 m in Standard Case XL	1 pc front	37.4 x 38.9	34
Classic Frame - counter, 1 m in Soft Bag	1 pc front	37.4 x 38.9	25
	2 pcs sides	13.3 x 38.9	

*Weight incl. Standard Case XL.

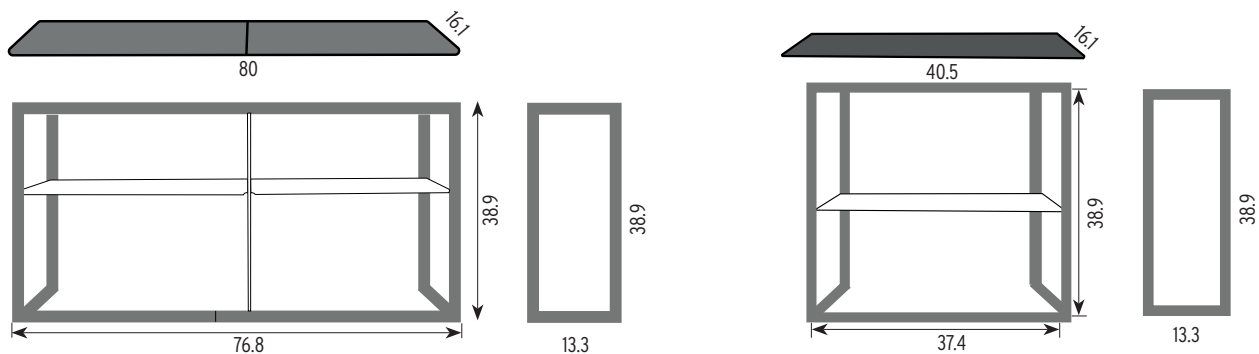

Fabric Stand

Product	Frame outer measurements	Weight
Fabric Stand with feet	39.2 x 78.6	10
Fabric Stand with Flat Base	39.2 x 78.6	13

Graphic size - frame outer measurements

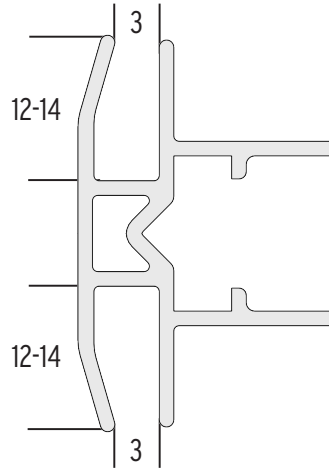
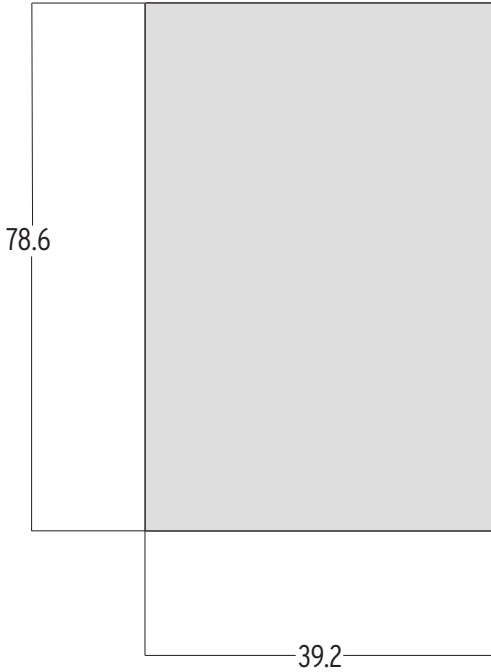

Recommended max size SEG strip (keder) 12-14mm x3mm

Monitor Stand

Product	Max screen weight	System height	Weight
Monitor Stand	33 lb (about 55" today)	71	30.8

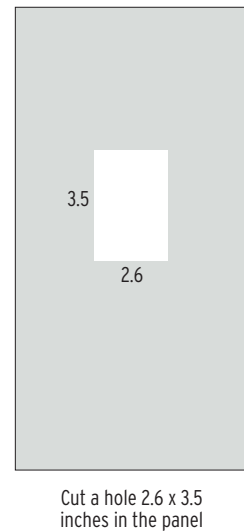
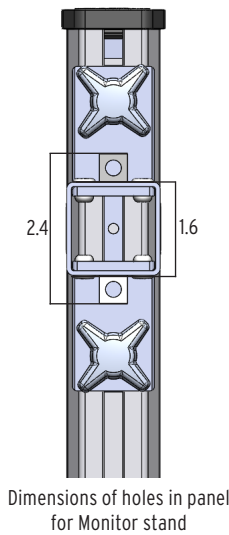
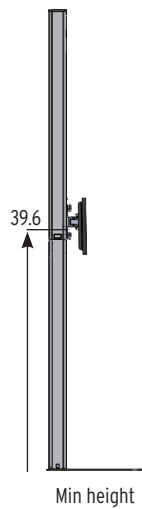
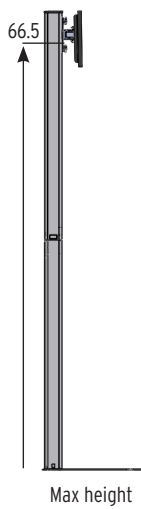

Light Frame Mini

Product	Frame outer measurements	Weight* (Basic)	Weight* (Travel)
Light Frame mini 2000	39.4 x 78.2	24.2	29.3
Light Frame mini 2340	39.4 x 91.6	26.4	31.5

Graphic size - frame outer measurements

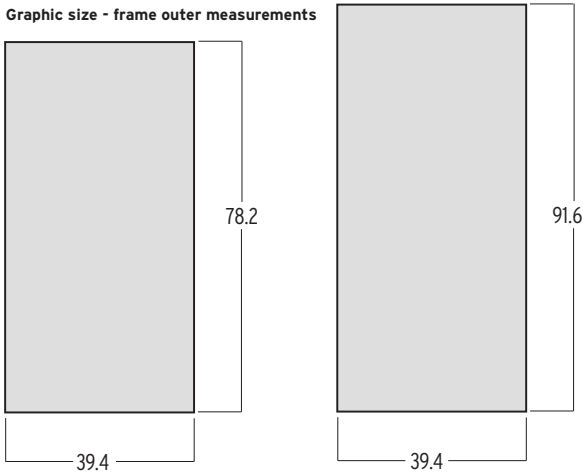

Recommended max size SEG strip (keder) 12-14mm x 3mm

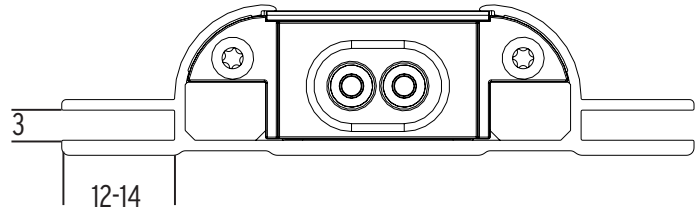

Light Frame Counter

Product	No of graphics	Outer frame sizes	Weight*
Light Frame Counter	1 pc front	39.4x39.9	41.8
	2 pcs sides	11.2x39.9	

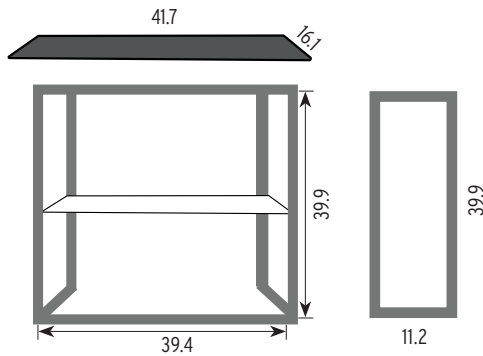

Recommended max size SEG strip (keder) 12-14mm x 3mm

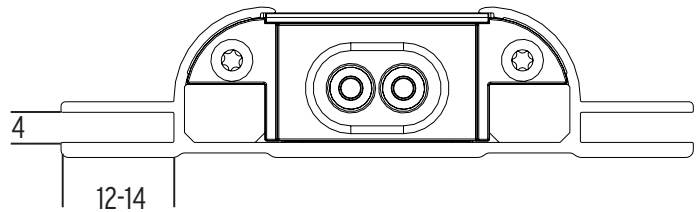

Fold Out Counter

Product	No of graphics	Outer frame sizes	Weight*
Fold Out Counter	1 pc front	39.3x38.7	36.3
	2 pcs sides	13,1x38,7	

Weight incl. Soft Bag with wheels.

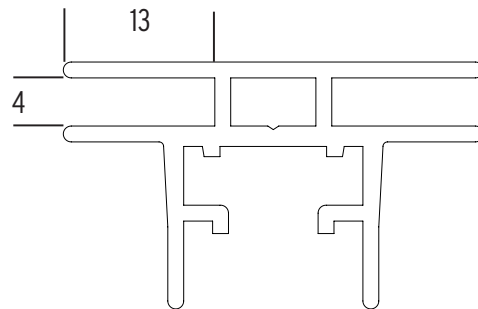
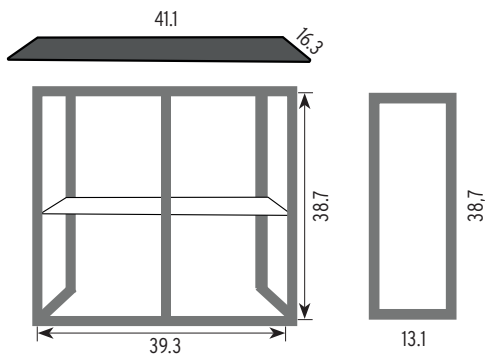

Recommended max size SEG strip (keder) 14x3mm

Flat Base

Product	Weight
Flat Base 400 #6440	2.4
Flat Base 610 #6461	2.7

Flat Base 400

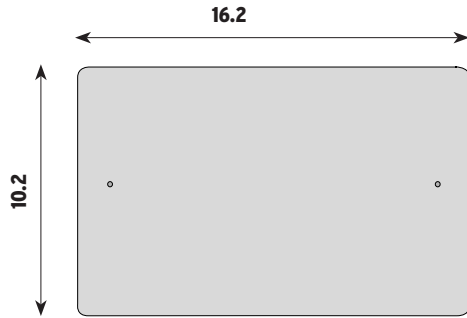

Flat Base 610



Magnet Frame

Product	Qty panels	Frame dimensions	Panel size with		Weight
			Flat Base	Panel Base	
15.7 x 63 #6421	2 pcs	15.9 x 62.6	15.7 x 62.4	15.7 x 60.4	4
15.7 x 70.8 #6422	2 pcs	15.9 x 70.5	15.7 x 70.3	15.7 x 68.3	4.2
24 x 63 #6431	2 pcs	24.2 x 62.6	24 x 62.4	24 x 60.4	4.4
24 x 70.8 #6432	2 pcs	24.2 x 70.5	24 x 70.3	24 x 68.3	4.6

Recommended panel thickness 350x420 micron.

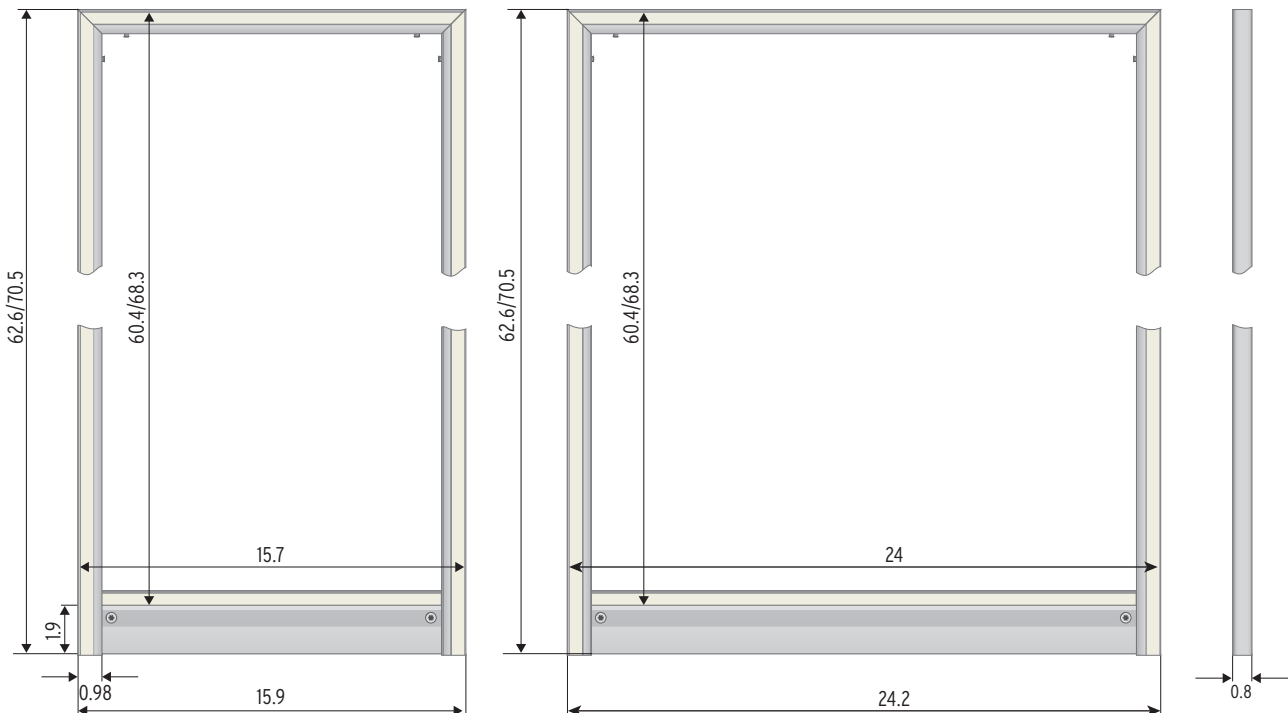

Panel Base

Product	Qty panels	Max panel thickness	Weight
Panel Base 80 3" #6401	1 pc	.75	1.5
Panel Base 400 15" #6404	1 pc	.75	3.7
Panel Base 610 24" #6406	1 pc	.75	5.5
Panel Base 916 36" #6409	1 pc	.75	6.2
Panel Base 1220 48" #6412	1 pc	*1.0	15

Panel Base can handle most materials up to .75" thickness. Recommended max panel height 84" depending on the material. Please note that 1" at the bottom will be invisible in the systems L-extrusion.

Panel Base 80



Panel Base 400

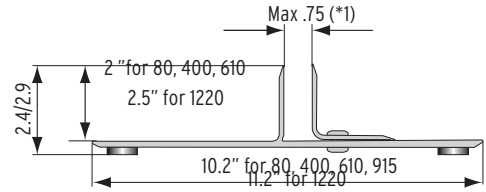
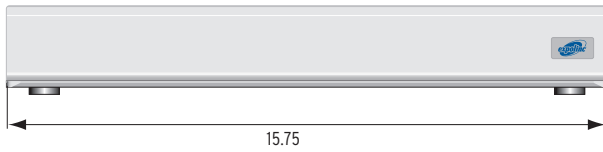

Panel Base 610/1220

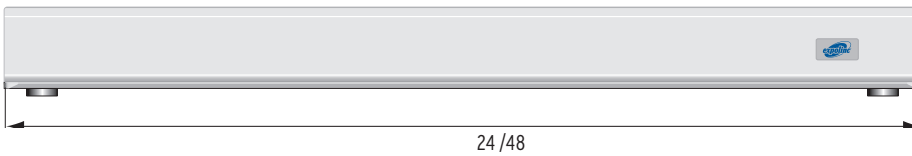

Stand Up

Product	Qty panels	Panel size	Visible size	Weight
Universal Counter #8502	1 pc	Front	27.1 x 37	38.5
	4 pcs	Sides	11.2 x 37	
Info Counter #8501	1 pc	Front	27.1 x 37	20.9
	2 pcs	Sides	11.2 x 37	

Maximum panel thickness 1/4". Use clips in thickness < 1/8".

Stand Up Universal Counter

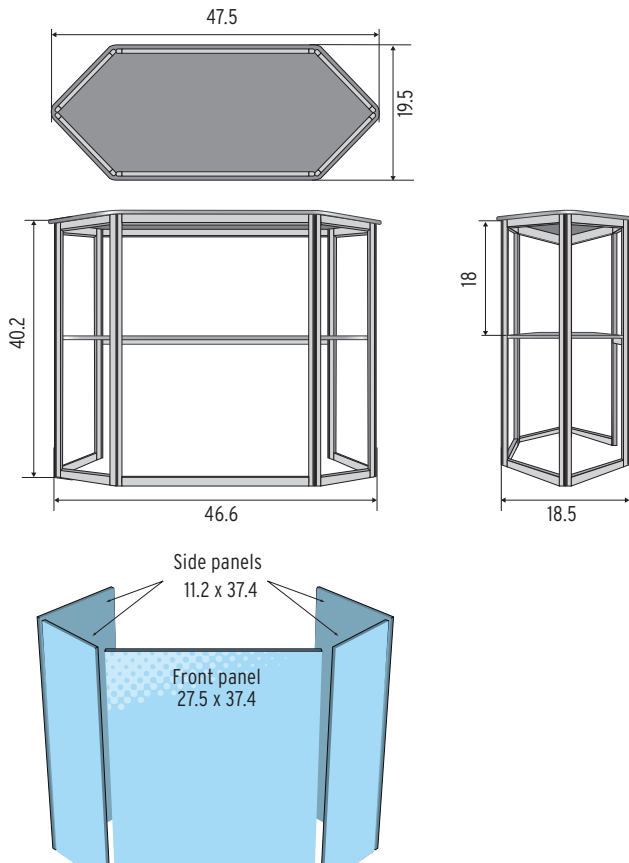

Stand Up Info Counter

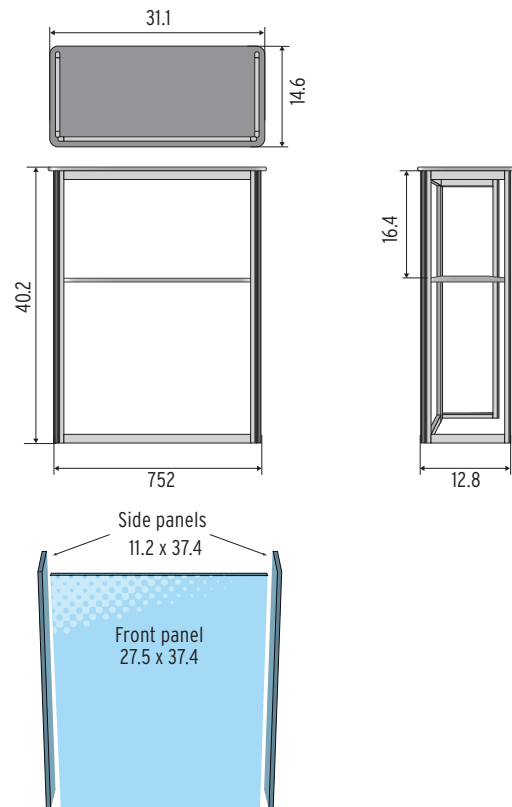

Soft Image

Product	Panel size front textile	Panel size covered sides	Weight*
Soft Image 2 x 2 #6222	59.8 x 59.4	84.5 x 59.4	12.0
Soft Image 1 x 3 #6213	29.7x 88.2	54.7 x 88.2	11.5
Soft Image 2 x 3 #6223	59.4 x 88.2	84.5x 88.2	15.4
Soft Image 3 x 3 #6233	88.2 x 88.2	113.4 x 88.2	20.3
Soft Image 4 x 3 #6243	116.4 x 88.2	142.1 x 88.2	24.6
Soft Image 5 x 3 # 6253	145.7 x 88.2	170.9 x 88.2	30.0

*Weight frame only. The above sizes are the actual sizes. As textile is elastic the size may vary.

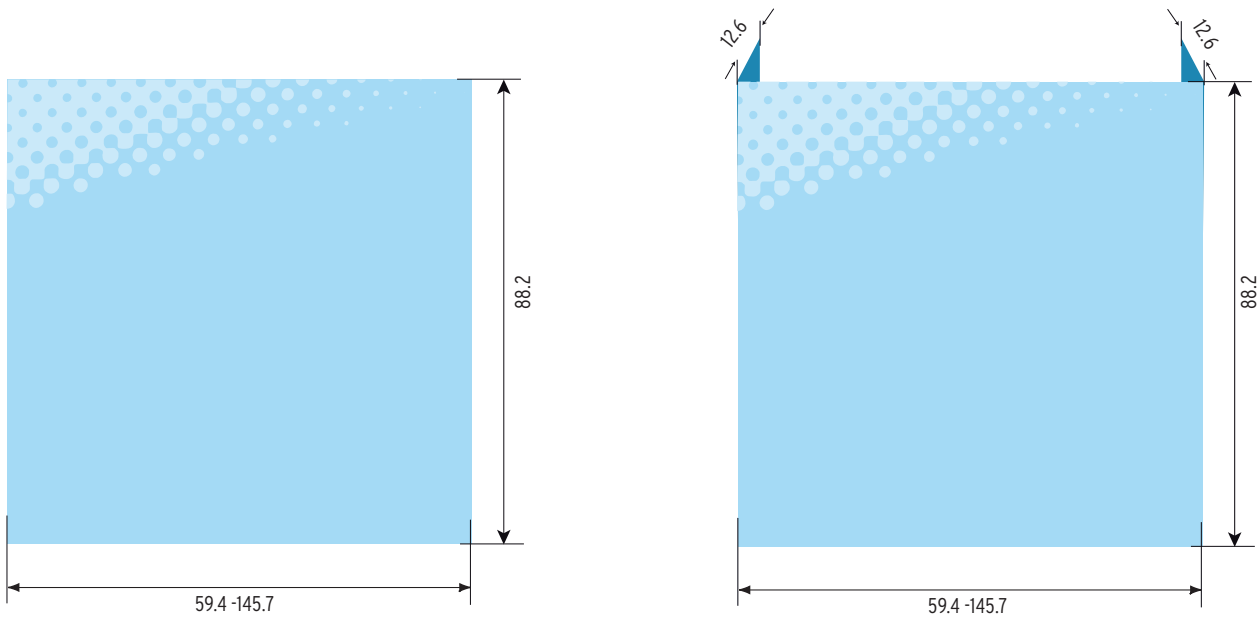

Soft Image Counter

Product	Size textile front and sides	Weight
Soft Image Counter alt 1	64.5 x 39	23
Soft Image Counter alt 2	68.5 x 39	23

The above sizes are the actual sizes. As textile is elastic the size may vary.

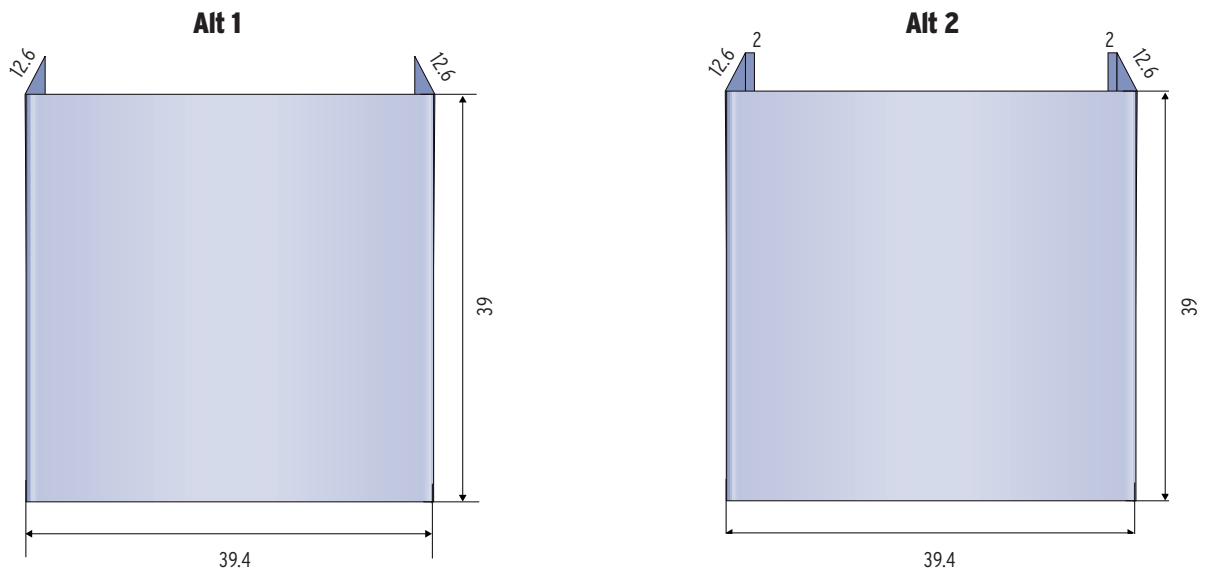

Info Stand & Portable Table

Product	Max image size	Visible size	Weight
Info Stand - straight #2800	11.7 x 16.5 (landscape)	11.2 x 16.5	10.5
Info Stand - angled #2801	8.3 x 11.7 (portrait) or 11.7 x 8.3 (landscape)	8.3 x 11.7 (portrait) or 11.7 x 8.3 (landscape)	11.5
Portable Table #7201			22.0

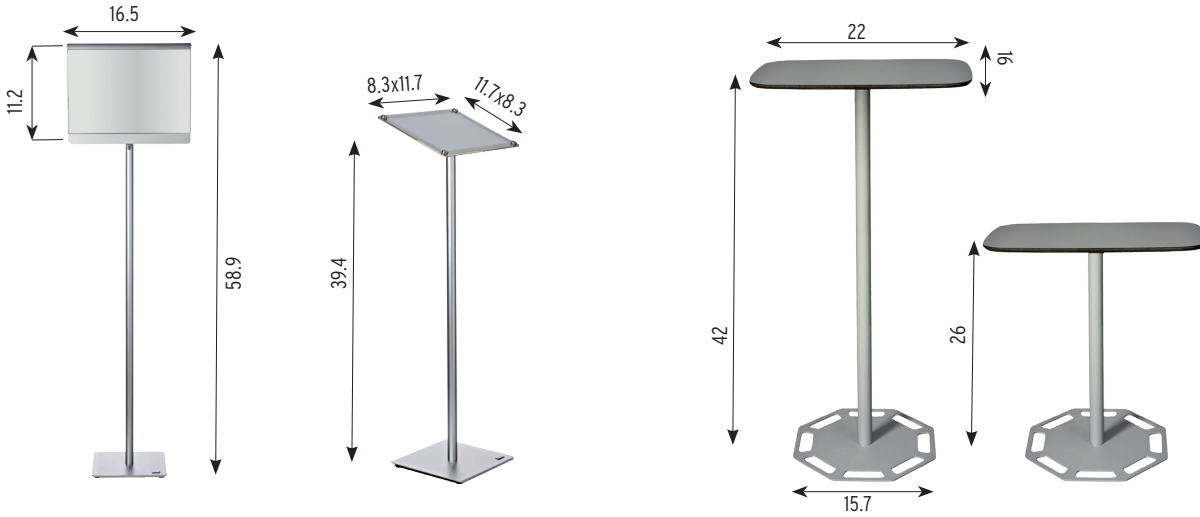

Brochure Stand

Product	Qty holders	Size of holder	Weight
Brochure Stand with soft bag #4500	4 pockets	8.7 x 13	11.0
Brochure Stand with hard case	4 pockets	8.7 x 13	18.5

Brochure Stand Double

Product	Qty holders	Size of holders	Weight
Brochure Stand Double with soft bag #2100	5 pockets	8.7 x 12	11.4
Brochure Stand Double with hard case	5 pockets	8.7 x 12	19.0

Graphic Profile

Product #4920	Max thickness	Weight
	mil	lb/ft
All versions	30	0.77

VISIT WWW.EXPOLINC.US FOR SET-UP MOVIES AND DOWNLOADS



WATCH OUR SET-UP MOVIES



HEAD OFFICE SWEDEN: EXPOLINC AB. ARCHIMEDESVÄGEN 6, SE-168 66 BROMMA. TEL +46-8-54644400. INFO@EXPOLINC.SE, WWW.EXPOLINC.COM
GERMANY, SWITZERLAND: EXPOLINC GMBH, SCHULZE-DELITZSCH-STR. 8, 68542 HEDDESHEIM. TEL +49(0)6203 938480, INFO@EXPOLINC.DE, WWW.EXPOLINC.DE
U S A: EXPOLINC CO., PO BOX 218, 1091 COUNTY ROAD 26, MARENGO, OH 43334 TOLL FREE 1-800-319-0025. INFO@EXPOLINC.US, WWW.EXPOLINC.US
AUSTRIA, CZECH REPUBLIC, HUNGARY: TEL: +43 660 644 0701, ROLAND@EXPOLINC.AT
FRANCE: TEL +33 (0) 6 59 47 98 54, DENIS@EXPOLINC.COM